

Nice

SOLEMYO OPERA BLUEBUS 24V

# Run 1500

For sliding gates weighing up to 1500 kg

Versions with electromechanical limit switch (RUN1500) and with inductive limit switch (RUN1500P).

**User-friendly:** thanks to the BlueBUS system, allowing the control unit to be connected to up to 7 pairs of photocells and control, security and signalling devices with just two wires.

**Practical:** the control unit and PS124 buffer battery (optional) can be connected by means of a simple connector and can be housed directly inside the motor.

**Advanced:** the temperature sensor adapts the motor force to weather conditions, setting the thermal cut-out protection accordingly; a master/slave selection automatically synchronises 2 motors, enabling the automation of sliding gates with two opposing leaves.

**Intelligent:** thanks to the obstacle detection system and automatic programming of the working times, Self-diagnosis by means of a flashing light, 8 programming levels.

**Safe:** acceleration and deceleration can be adjusted at the beginning and at the end of each opening and closing manoeuvre.

**Sturdy:** base and release in pressure die cast with easy to open handle.

**Silent:** gear motor on bearings.



## COMMON ACCESSORIES



**IBT4N**  
Interface for connecting the O-View programming unit.

Pc./Pack 1



**IT4WIFI**  
Smart Wi-fi interface to manage gates and garage doors by smart-phone (\*).

Pc./Pack 1



**RBA3**  
Spare control unit for RB400, RB600/600P, RB1000/1000P and RUN1500/1500P.

Pc./Pack 1



**PS124**  
24 V battery with integrated battery charger.

Pc./Pack 1



**RBA1**  
Inductive limit switch.

Pc./Pack 1



**ROA7**  
M4 rack, zinc coated, 22x22x1000 mm.

Pc./Pack 10



**ROA8**  
M4 rack, 30x8x1000 mm, zinc coated with spacers and screws.

Pc./Pack 10



**ROA81**  
M6 rack, 30x30x1000 mm, zinc coated, to be coupled with RUA12.

Pc./Pack 10



**RUA12**  
12-teeth pinion, module 6, to be coupled with rack ROA81. The Run automation is supplied with a module 4 pinion to be used with the standard racks ROA7 and ROA8.

Pc./Pack 1



**TS**  
Signboard.

Pc./Pack 1



**SOLEMYO KIT**  
The solar power to automate gates, garage doors or barrier gates.

See page 213.

\* Not compatible with the Solemyo kit and PS124

## TECHNICAL SPECIFICATIONS

Code	Description	Pack/Pallet
<b>RUN1500</b>	Irreversible, 24 Vdc, with built-in control unit, with electromechanical limit switch, for sliding gates weighing up to 1500 kg	12
<b>RUN1500P</b>	Irreversible, 24 Vdc, with built-in control unit, with inductive limit switch, for sliding gates weighing up to 1500 kg	12

Code	RUN1500/1500P
<b>ELECTRICAL DATA</b>	
Power supply (Vac 50/60 Hz)	230
Absorption (A)	2
Power (W)	400
<b>PERFORMANCE DATA</b>	
Speed (m/s)	0,25
Force (N)	1000
Work cycle (cycles/hour)	60
<b>DIMENSIONAL AND GENERAL DATA</b>	
Protection level (IP)	44
Working temp. (°C Min/Max)	-20 ÷ +50
Dimensions (mm)	400x255x390 h
Weight (kg)	19

## DIMENSIONS

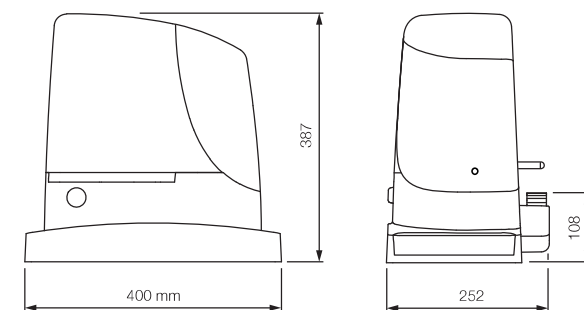

## COMPATIBILITY TABLE WITH CONTROL SYSTEMS AND ACCESSORIES

Code	receiver		transmitter		photocells								flashing light									
	Built-in*	OXI	ERA INTI	ERA ONE	ERA FLOR	NICEWAY	EPS	EPIM	EPL	EPSB	EPMB	EPLB	EPMOV	EPMOR	F210	F210	F210B	FT210B	ELAC	ELDC	WLT	
<b>RUN1500/1500P</b>		•	•	•	•	•					•	•	•	•			•	•		•	•	•

\* Radio receiver incompatible with Opera system