

Nice

SOLEMYO OPERA BLUEBUS 24V

# Slight

Nice motor for sliding gates up to 400 kg with leaf length up to 6 m

Motor with built-in control unit and absolute encoder.

**Innovative ultra-compact design:** the vertical configuration of the motor makes it easy to install even in narrow openings.

**User-friendly:** thanks to the BlueBUS system, allowing the control unit to be connected to up to 7 pairs of photocells and control, security and signalling devices with just two wires.

**Built-in LED light:** programmable as either a flashing or courtesy light, it warns of gate movement during opening and closing.

**Master/slave selection:** for automatic synchronisation even of 2 motors, allowing automation of sliding gates with two opposing leaves.

**Intelligent:** thanks to obstacle detection and automatic working time programming. Self-diagnostics with flashing light signalling.

**Safe:** acceleration and deceleration can be adjusted at the beginning and at the end of each opening and closing manoeuvre.

**Built-in absolute limit stop:**

- simple and precise regulation thanks to the rapid learning in a single movement with the motor released;
- no bracket or accessory to be installed on the ratchet;
- particularly suitable in snow areas.

**Practical:** control unit and optional PS124 buffer batteries can be connected by means of practical guided - connector.



Courtesy  
or flashing  
LED light

## COMMON ACCESSORIES



**IBT4N**  
Interface for connecting the O-View programming unit.  
Pc./Pack 1



**IT4WIFI**  
Smart Wi-fi interface to manage gates and garage doors by smart-phone (\*).  
Pc./Pack 1



**NKA3**  
Spare control unit.  
Pc./Pack 1



**PS124**  
24 V battery with integrated battery charger.  
Pc./Pack 1



**ROA6**  
M4 25x20x1000 mm slotted nylon rack with metal insert. For gates weighing up to 500 kg.  
Pc./Pack 10



**ROA7**  
M4 rack, zinc coated, 22x22x1000 mm.  
Pc./Pack 10



**ROA8**  
M4 rack, 30x8x1000 mm, zinc coated with spacers and screws.  
Pc./Pack 10



**TS**  
Signboard.  
Pc./Pack 1



**SOLEMYO KIT**  
The solar power to automate gates, garage doors or barrier gates.

See page 213.

\* Not compatible with the Solemyo kit and PS124

## TECHNICAL SPECIFICATIONS

Code	Description	Pack/Pallet
<b>SLH400</b>	Irreversible, 24 Vdc, with built-in control unit and absolute encoder with built-in LED light	16

Code	SLH400
<b>ELECTRICAL DATA</b>	
Power supply (Vac 50/60 Hz)	230
Absorption (A)	1,1
Power (W)	250
<b>PERFORMANCE DATA</b>	
Speed (m/s)	0,34
Force (N)	400
Work cycle (cycles/hour)	35
<b>DIMENSIONAL AND GENERAL DATA</b>	
Protection level (IP)	44
Working temp. (°C Min/Max)	-20 ÷ +50
Dimensions (mm)	131x135x405 h
Weight (kg)	6,5

## DIMENSIONS

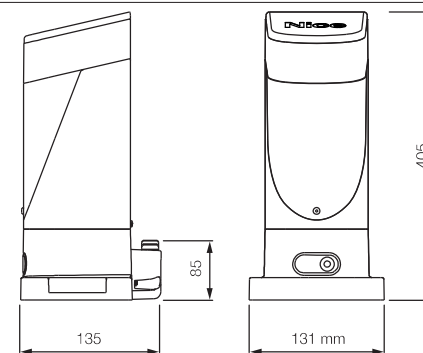

## COMPATIBILITY TABLE WITH CONTROL SYSTEMS AND ACCESSORIES

Code	receiver		transmitter			photocells						flashing light										
	Built-in*	OXI	ERA INTI	ERA ONE	ERA FLOR	NICEWAY	EPS	EPM	EPL	EPSS	EPMB	EPLB	EPMOW	EPMOR	F210	F210	F210B	F210B	ELAC	ELDC	WLT	
<b>SLH400</b>		•	•	•	•	•				•	•	•	•	•			•	•		•	•	•

\* Radio receiver incompatible with Opera system